

INSTALLATION

The following instructions describe methods that can be used to attach your Torflex axles to the vehicle frame.

Step 1: The user must first decide where to place the axle(s) on the trailer. The position of the wheel center relative to the CG (center of gravity) will determine the final axle loading as well as the hitch load.

Step 2: Determine the method of attachment you wish to use.

- a. For structural tube type frame rails, refer to figure 1 for the recommended attachment.
- b. For "C" channel or "I" beam type frame, refer to figure 2.

Step 3: Once the method of attachment is decided, the axle(s) must be carefully aligned on the trailer frame. The axle(s) centerline must be perpendicular to the longitudinal centerline of the trailer. See figure 3.

⚠ CAUTION:

Misalignment of the axle(s) can cause poor tracking and accelerated tire wear.

Attachment to Structural Tube Type Frame

- a. Dexter Axle recommends the use of side mounting hangers when mounting axles to tubular type frames. These hangers provide a convenient means for bolting the axles in place. All of the necessary components are included in the Side Mount AP kits listed in Chart 1.
- b. Refer to Chart 2 to find the mounting bracket dimensions of your axles. This chart shows the dimensions from the wheel center to the bolt holes of the brackets.
- c. The preferred way to use the side mount hanger is to pre-assemble the hangers to the axle using the hardware provided in the AP kit. Make sure the hangers are clamped firmly against the axle brackets and the bolts are tightened to the torque specifications shown in Chart 1. Position the axle assembly on the frame rails in the desired location and weld the side mount hangers to the frame.
- d. Axle bracket position is the distance as measured over the outboard edges of the brackets. This dimension is usually matched to the outside measurement of the frame members but depending on the type of frame may not always be suitable. The preferred arrangement should place the longest vertical section of the axle bracket directly under the most rigid section of the frame member.

Side Mount Installation

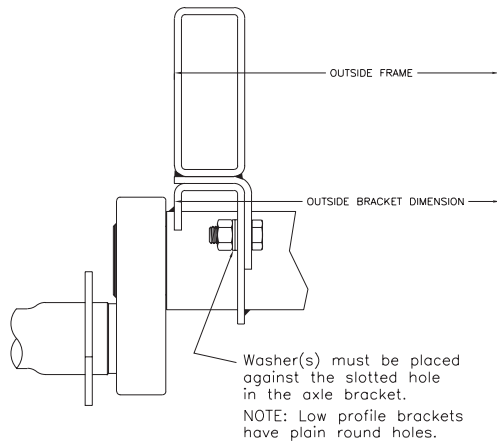

Figure 1

Side mount hangers should be welded to frame with three (3) ¼" fillet welds, 2½" long on each side of the hanger and a fillet weld on each end. Welds should meet the quality standards of the American Welding Society, D1.1, Structural Welding Code.

**Chart 1
Attaching Parts Kits and
Torque Specifications**

Axle Size	A/P-Kit Top Mt.	A/P-Kit Side Mt.	Bolt Size	Torque Lb-Ft.
#8	A/P-161-00	A/P-165-00	1/2"	70-90
#9	A/P-161-00	A/P-165-00	1/2"	70-90
#10	A/P-148-00	A/P-166-00	5/8"	120-155
#11	A/P-148-00	A/P-167-00	5/8"	120-155
#12	A/P-148-00	A/P-168-00	5/8"	120-155
#13	A/P-148-00	A/P-169-00	5/8"	120-155

Side mount hangers and fasteners for mounting axle are provided in AP (attaching parts) kit shown in Chart 1. Torque fasteners to levels specified in Chart 1.

Attachment to "C" Channels or "I" Beam Type Frame

- a. Refer to Chart 2 to find the mounting bracket dimensions of your axles. This chart shows the dimensions from the wheel center to the bolt holes of the brackets.
- b. Lay-out the bolt hole locations on the bottom flanges of the frame rails. Make sure the hole pattern matches the mounting brackets of your axles and is properly oriented to allow proper alignment of the axle(s).
- c. An alternate method for determining hole location is to position the axle assembly on the frame rails, align it perpendicular to the trailer centerline, clamp in place and transfer the holes directly from the brackets.
- d. Drill the holes through the frame rails and attach the axle using the hardware provided in the AP kit. Tighten the bolts to the torque specified in Chart 1.

⚠ CAUTION:

When bolting to structural shapes that have tapered flanges, bevel washers must be used to prevent uneven clamping and bending of the fasteners.

NOTE: In the unlikely event a Torflex axle must be replaced during the warranty period, Dexter Axle cannot assume responsibility for additional costs incurred for removal and re-installation of axles that have been welded directly to the frame.

Top Mount Installation

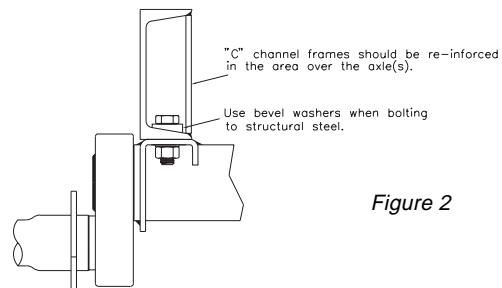

Figure 2

⚠ CAUTION:

"C" channel and "I" beam type frame sections should be reinforced in the area over the axle mounting brackets. It is recommended that the vertical leg of the axle bracket be positioned directly under the vertical segment or reinforcement of the frame member.

**Chart 2
Bracket Dimensions**

Fender clearance: allow 3" over the tire at full load

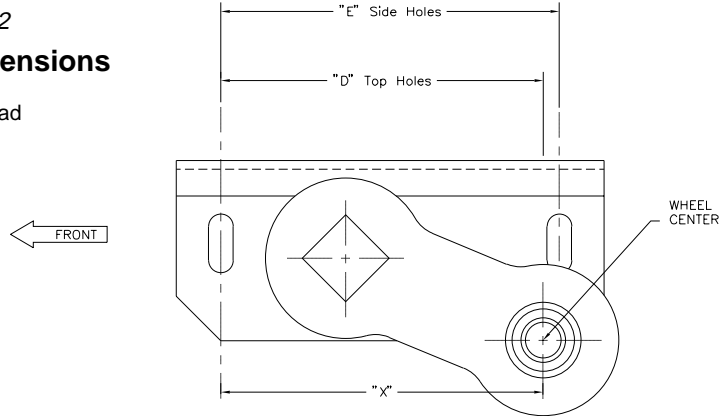

Torflex Axle Model	Mounting Hole to Wheel Center - Dimension "X" (inches)												Mounting Hole Spacing Inches	
	Start Angle of Trailing Arm													
	45° DN		22.5° DN		10° DN		0°		10° UP		22.5° UP		Dim "D" (Top)	Dim "E" (Side)
	No Load	Full Load	No Load	Full Load	No Load	Full Load	No Load	Full Load	No Load	Full Load	No Load	Full Load		
#8 (4" arm)	5.21	6.08	6.08	6.38	6.32	6.29	6.38	6.08	6.32	5.75	6.08	5.21	7.75	8.00
#9 (6" arm)	6.62	7.92	7.92	8.38	8.29	8.24	8.38	7.92	8.29	7.44	7.92	6.62	7.75	8.00
#10 (6" arm)	6.74	8.04	8.04	8.50	8.41	8.36	8.50	8.04	8.41	7.56	8.04	6.74	8.00	8.00
#11 (6" arm)	7.74	9.04	9.04	9.50	9.41	9.36	9.50	9.04	9.41	8.56	9.04	7.74	9.00	9.50
#12 (6" arm)	7.74	9.04	9.04	9.50	9.41	9.36	9.50	9.04	9.41	8.56	9.04	7.74	9.00	9.50
#13 (6" arm)	7.84	9.17	9.17	9.63	9.54	9.49	9.63	9.17	9.54	8.69	9.17	7.87	10.56	10.56

Axle Alignment

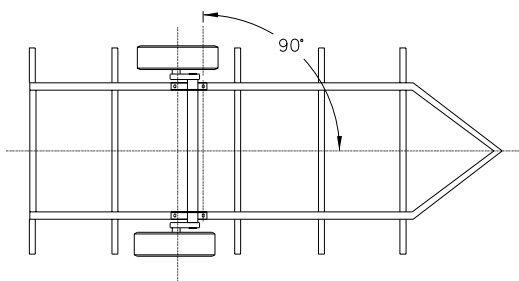

Figure 3

To insure proper tracking, the axle must be placed on the frame perpendicular to the centerline of the vehicle. The accuracy must be within plus or minus one half degree. For multiple axle applications, each axle must be parallel with the others within one sixteenth of an inch when measured at the wheel centers.

⚠ CAUTION:

When laying out the position for the axle(s), measuring from the front cross member should only be done if the cross member has been checked for squareness to the frame centerline. Any error in the cross member will be transferred to the axle and can result in poor tracking and excessive tire wear.